

Stromlaufplan (6V) TS 250, 250/1 deluxe

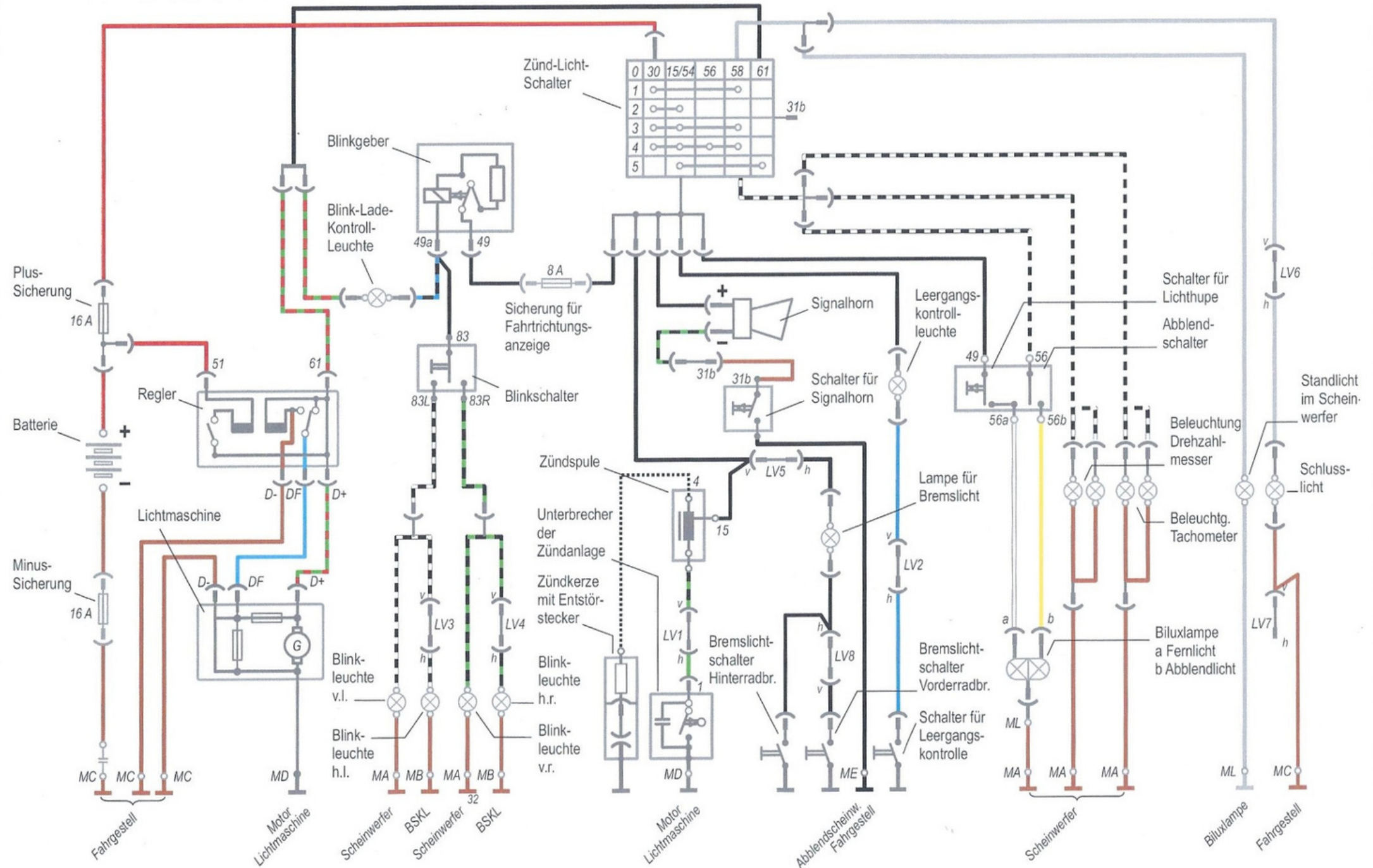

MZ TS 250, 250/1 de luxe

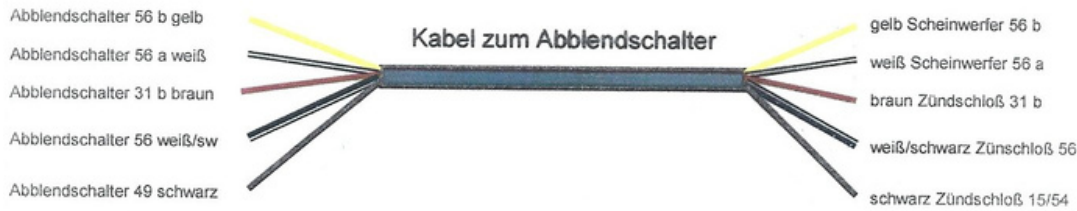
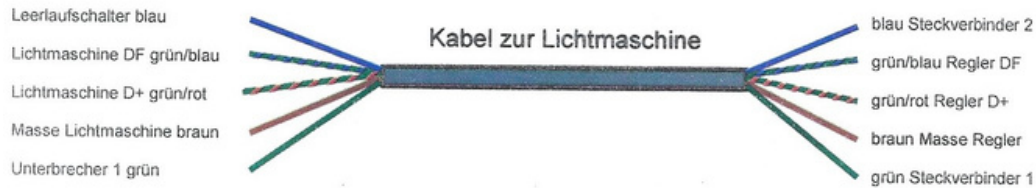

MZ TS 250 und TS 250/1 de luxe

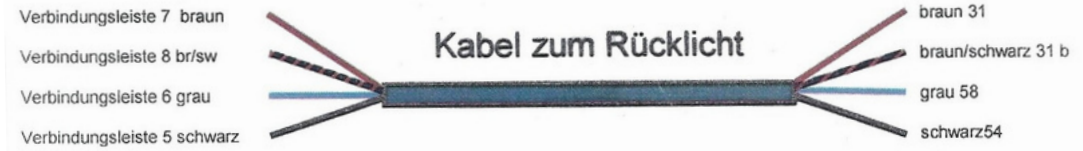

Einzelkabel für Blinker

Masse Lampe braun 5 mm	370 mm	braun Blinker vorn links
Masse Lampe braun 5 mm	370 mm	braun Blinker vorn rechts
Masse Rücklicht braun 6 mm	210 mm	braun Blinker hinten links
Masse Rücklicht braun 6 mm	210 mm	braun Blinker hinten rechts
Sicherung Blinker schwarz	100 mm	schwarz Blinkgeber 49

Kabel einzeln

Verbindungsleiste 1 schwarz/grün	340 mm	schwarz/grün Zündspule 1
Verbindungsleiste 7 braun	160 mm	braun Masse Regler
Verbindungsleiste 8 braun/sw	1020 mm	braun/schwarz Stoplichtschalter
Sicherungsklemmbrett 31 braun	130 mm	braun Masse Regler
Sicherungsklemmbrett 30 rot	210 mm	rot Regler 51
Sicherungsklemmbrett 30 rot	250 mm	rot Batterie 5 mm
Sicherungsklemmbrett 31 braun	270 mm	braun Batterie 5 mm
Scheinwerfer 31 braun	210 mm	braun Masse Lampe